

VBX Wellness

**VBX 5000
VIBRATION EXERCISE
MACHINE**



WWW.VBXWELLNESS.COM | VBXWELLNESS@GMAIL.COM
952.884.0326

Table of Contents

Safety Information	02
Specifications	03
Machine Diagram	04
Assembly Instructions	04-05
Control Panel Diagram	06
Control Panel Operation	07
Warranty Information	08
Quick Reference	08

Safety Information

BEFORE USE...

- Check the exercise speed before operating to ensure it's at a safe and comfortable level for you.
- Hold the safety handle before beginning the program to ensure your balance.
- Keep a recommended gap of 30cm between your feet in the initial stages.
- Prior to cleaning the machine, make sure the machine is off and the power cord is unplugged.
 - **NOTE:** Using corrosive cleaner is prohibited. **Do not** use benzene or thinner to clean the machine. **Do not** spray insecticide on the machine.
- When the machine is not in use, turn off the power and unplug the power cord, to both save energy and reduce the risk of fire.
- When the machine is not in use, use a cover to protect the vibration plate from accumulating dust.

USE CAUTION

- **IMMEDIATELY DISCONTINUE USE IF YOU HAVE ANY DISCOMFORTS AND DO NOT RESUME USE UNTIL CONSULTING A PHYSICIAN.**
- **Do not** coil the power cords, as this may cause the machine to malfunction and could damage the power cords.
- **Do not** exercise in the same pose for more than ten (10) minutes, as this may result in muscle cramping.
- **Do not** operate the machine with more than one person at a time, as this may result in injury or machine damage.
- **Do not** operate the machine with wet hands, as this could cause an electric shock.
- **Do not** reduce or use force to relocate the product, as this may cause damage to the machine.
- **Do not** store the vibration plate near heat or open flame; in direct sunlight or high temperatures for a prolonged period of time; or in humidity.
- **Do not** use any kind of sharp tools (i.e. knife) on the vibration plate.
- **Do not** use the machine 30 minutes before and after eating a meal.
- **Do not** use the machine for any purpose other than exercise.
- **Do not** use the machine in wet areas (i.e. bathroom), as this may result in electrical shock.
- **Do not** use the vibration plate for any purpose other than its intended use, as described in this manual.

Specifications

Machine Color	Black
Light Color	Blue / Red
Machine Height	66"
Machine Weight	165 lbs
Max Weight Capacity	500 lbs
Footprint	30" x 26"
Base Height	8.5"
Base Amplitude	10mm
Frame Construction	Steel
Motor	2: Horizontal, Linear
Motor Horsepower	2.0 HP Duty
Motor Wattage	800W/ea
Vibration Speeds	120
Vibration Force	17.2 G's
Operating Frequency	1Hz-60Hz
Programs	6: 3 Pre-Programmed, 3 User Defined

Machine Diagram

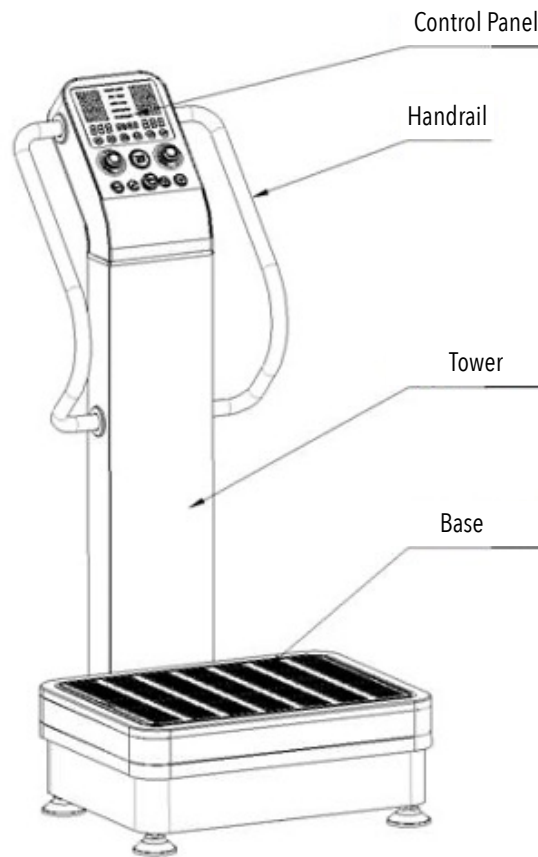

Assembly Instructions

1. Take the machine out of the box.
 - **NOTE:** The base is extremely heavy. We recommend two people removing it from the packaging.
 - **NOTE:** We recommend having one person hold the tower firmly, while the other connects the signal lines.
2. Attach the base and tower together.
 - **NOTE:** Use care when attaching the pieces, as they can jam the signal cables, which will result in the machine not working as intended.
3. Fasten the tower with part #4 (qty: 10), part #5 (qty: 10), and part #6 (qty: 10), 5pcs per side.
Tighten the screws.

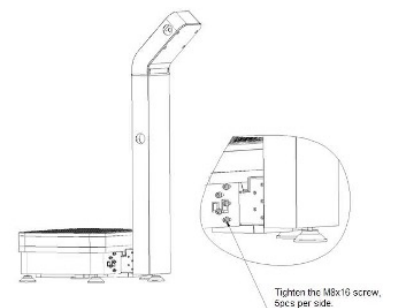
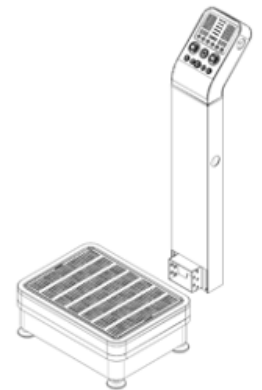

4. Using part #1 (qty: 4), screw the metal deco cover on to the base, 2pcs per side.

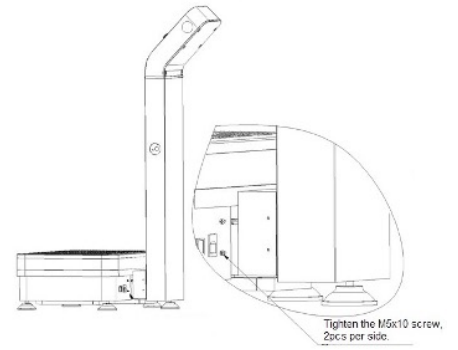
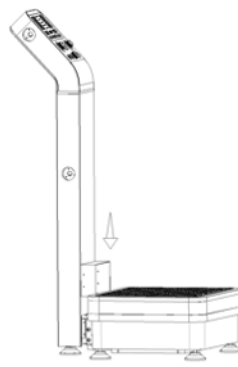

5. Align the handrail flange with the screw hole on the tower. Using part #3 (qty: 8), screw the handrails onto the tower, 4pcs per side. Tighten the screws.

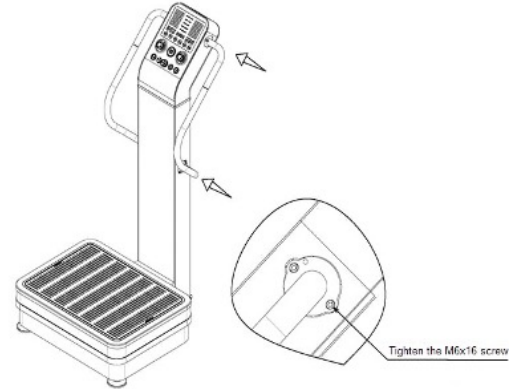

6. Install the decorative ring covers onto the handrails, using part #2 (qty: 8), 4pcs per side.

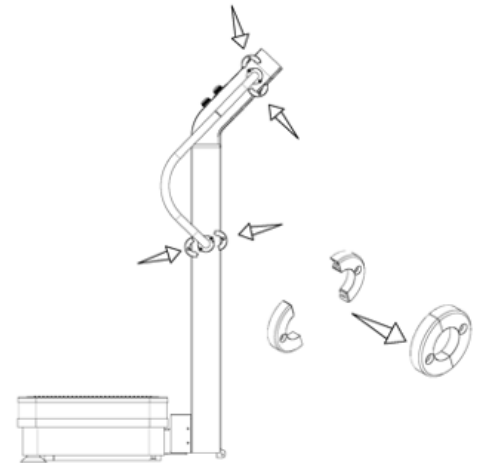

7. Enjoy your new VBX machine!

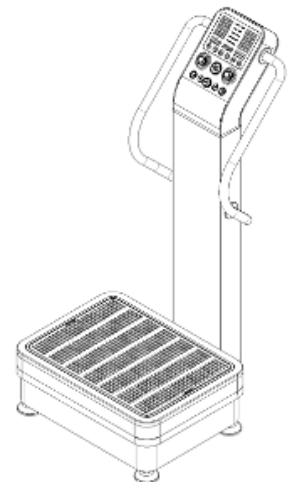

Control Panel Diagram

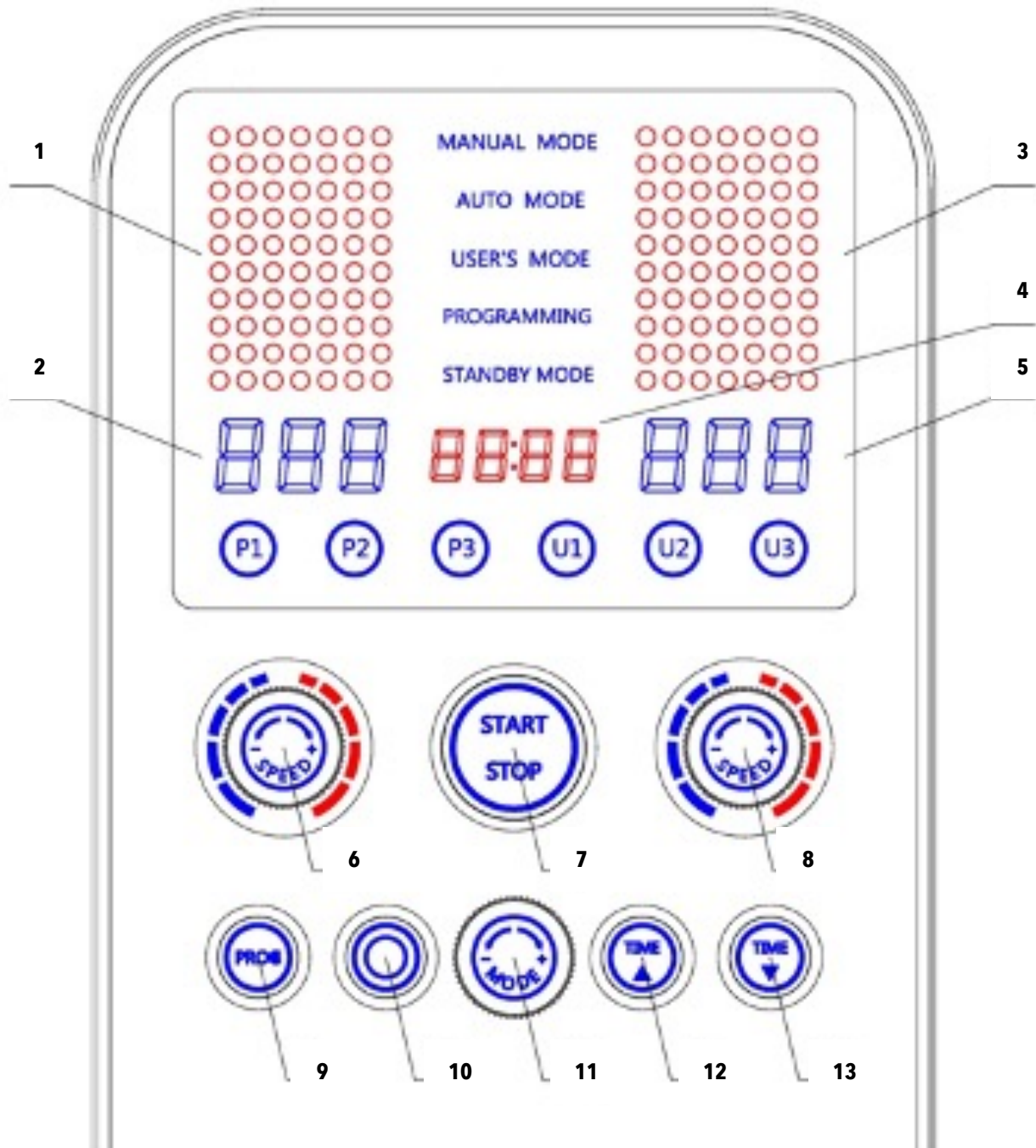

Control Panel Operation

1. The **horizontal vibration time display** displays the horizontal vibration time or displays the horizontal and linear vibration times combined. The preset time is 0-20 minutes.
2. The **horizontal vibration speed display** displays the horizontal vibration speed, ranging from H00-H60
 - **NOTE:** When the display reads "H00", the linear vibration will not work.
3. The **linear vibration time display** displays the linear vibration time or displays the linear and horizontal vibration times combined. The preset time is 0-20 minutes.
4. The **time indicator** indicates the time.
5. The **linear vibration speed display** displays the linear vibration speed, ranging from L00-L60
 - **NOTE:** When the display reads "L00", the horizontal vibration will not work.
6. The **horizontal vibration switch & speed knob** will adjust the horizontal vibration speed or start/stop the horizontal vibration.
 - To increase speed, rotate the knob clockwise. To decrease speed, rotate the knob counter-clockwise.
 - To start or stop vibration, press the knob.
7. The **start/stop button** turns the machine on and off.
8. The **linear vibration switch & speed knob** will adjust the linear vibration speed or start/stop the linear vibration.
 - To increase speed, rotate the knob clockwise. To decrease speed, rotate the knob counter-clockwise.
 - To start or stop vibration, press the knob.
9. The **program button** programs your workout into the machine's memory. P1-P3 are default automatic programs, U1-U3 are user defined programs.
 - Rotate the 'MODE' knob to choose the program set desired (U1-U3).
 - Press 'PROG' to start programming.
 - Press 'TIME' to set the time for the current speed.
 - Press the left 'SPEED +/-' knob to set the horizontal vibration speed. Rotate to adjust.
 - Press the right 'SPEED +/-' knob to set the linear vibration speed. Rotate to adjust.
 - Press 'PROG' to confirm settings.
 - Repeat as needed until the program is set to your satisfaction.
10. The **standby button** will pause the machine. Press the start/stop button to resume.
11. The **mode selection knob** lets you choose between the different program modes (P1-P3, U1-U3) by rotating the knob.
12. The **time up button** increases the time. The starting default time is ten (10) minutes and the maximum adjustment is twenty (20) minutes.
13. The **time down button** decreases the time. The starting default time is ten (10) minutes and the maximum adjustment is twenty (20) minutes.

Warranty Information

FIVE (5) YEAR - Limited Warranty

The manufacturer warrants that this machine, when subject to normal and proper use, will be free from manufacturing defects for a period of five (5) years from the date of purchase. Should any defect occur during the specified time period, the manufacturer will repair the defective product, or provide replacement parts and components material, at its own option. The manufacturer also reserves the right to issue a full refund of the purchase price in lieu of repair or replacement. **This warranty is not transferable.** This warranty replaces all other oral or written warranties, liabilities or obligations of the manufacturer. Pertinent state law shall control for what period of time following the purchase a consumer may seek a remedy under the implied warranty of merchantability or fitness for a particular purpose. In no event shall the manufacturer be liable for consequential or incidental damages of any kind resulting from the breach of this warranty. Some states do not allow limitations on - or the exclusion of - incidental or consequential damages, so the above exclusions may not apply to you. This warranty gives you specific legal rights, and you may also have other rights which vary from state to state.

Quick Reference

The 'H' (horizontal) vibration is the *triangular oscillation vibration*, which is good for muscle contraction. This type of vibration is the one that gives you a workout.

The 'L' (linear) vibration is the more subtle *spiral vibration*, which is more therapeutic than the 'H' vibration. It helps improve circulation, reduce inflammation, assists with muscle recovery, etc.

Using both vibrations at once intensifies the effect of each vibration. There really isn't a "magic" way to use the machine; the most important part is using it consistently - which is how you'll see the best results.

Different users will use the machine at different speeds. An elderly person, for example, would use the machine at lower speeds while an elite athlete would use higher speeds. As a general recommendation, start out at speeds below 30 for the first few weeks of use and slowly go faster and faster as your body allows. Experimenting with varying speeds is also good to do, as different speeds affect your body differently. This is where the preset programs (P1-3) come in handy - they change the speed automatically and frequently, which gives your body a different stimulus than simply maintaining a consistent speed. When keeping the speed consistent, pick five (5) different positions (see pg. 9-12) and hold each position for 1-2 minutes. When the speed varies, stand with legs straight, bend your knees slowly, hold it, and return to the starting position.

It's recommended to use the machine twice per day: in the morning, use a consistent speed, and in the evening, utilize the varying speeds. Be sure to give your body at least one day of rest per week. Be careful not to overdo it in the beginning; this is a common mistake.

VBXWellness

VBX Wellness is a registered brand of M&E Sales, LLP

**150 W 88th St, Ste 114
Bloomington MN 55420**

**952.884.0326
vbxwellness@gmail.com**