

**VBX Wellness**

**VBX 4000  
VIBRATION EXERCISE  
MACHINE**



[WWW.VBXWELLNESS.COM](http://WWW.VBXWELLNESS.COM) | [VBXWELLNESS@GMAIL.COM](mailto:VBXWELLNESS@GMAIL.COM)  
952.884.0326

# Table of Contents

|                                 |       |
|---------------------------------|-------|
| Safety Information              | 02    |
| Specifications                  | 03    |
| Machine Diagram                 | 04    |
| Assembly Instructions           | 04    |
| Display & Control Panel Diagram | 05    |
| Control Panel Operation         | 05-06 |
| Modes & Programs                | 06-07 |
| Operating Instructions          | 07    |
| Warranty Information            | 08    |
| Quick Reference                 | 08    |

## Safety Information

### BEFORE USE...

- Check the exercise speed before operating to ensure it's at a safe and comfortable level for you.
- Hold the safety handle before beginning the program to ensure your balance.
- Keep a recommended gap of 30cm between your feet in the initial stages.
- Prior to cleaning the machine, make sure the machine is off and the power cord is unplugged.
  - **NOTE:** Using corrosive cleaner is prohibited. **Do not** use benzene or thinner to clean the machine. **Do not** spray insecticide on the machine.
- When the machine is not in use, turn off the power and unplug the power cord, to both save energy and reduce the risk of fire.
- When the machine is not in use, use a cover to protect the vibration plate from accumulating dust.

### USE CAUTION

- **IMMEDIATELY DISCONTINUE USE IF YOU HAVE ANY DISCOMFORTS AND DO NOT RESUME USE UNTIL CONSULTING A PHYSICIAN.**
- **Do not** coil the power cords, as this may cause the machine to malfunction and could damage the power cords.
- **Do not** exercise in the same pose for more than ten (10) minutes, as this may result in muscle cramping.
- **Do not** operate the machine with more than one person at a time, as this may result in injury or machine damage.
- **Do not** operate the machine with wet hands, as this could cause an electric shock.
- **Do not** reduce or use force to relocate the product, as this may cause damage to the machine.
- **Do not** store the vibration plate near heat or open flame; in direct sunlight or high temperatures for a prolonged period of time; or in humidity.
- **Do not** use any kind of sharp tools (i.e. knife) on the vibration plate.
- **Do not** use the machine 30 minutes before and after eating a meal.
- **Do not** use the machine for any purpose other than exercise.
- **Do not** use the machine in wet areas (i.e. bathroom), as this may result in electrical shock.
- **Do not** use the vibration plate for any purpose other than its intended use, as described in this manual.

# Specifications

|                            |   |
|----------------------------|---|
| <b>Machine Color</b>       | Black   |
| <b>Light Color</b>         | Blue  |
| <b>Machine Height</b>      | 58"   |
| <b>Machine Weight</b>      | 126 lbs   |
| <b>Max Weight Capacity</b> | 400 lbs   |
| <b>Footprint</b>           | 26" x 20"   |
| <b>Base Height</b>         | 8.5"  |
| <b>Base Amplitude</b>      | 10mm  |
| <b>Frame Construction</b>  | Steel   |
| <b>Motor</b>               | 2: Horizontal, Linear   |
| <b>Motor Horsepower</b>    | 2.0 HP Duty   |
| <b>Motor Wattage</b>       | 800W  |
| <b>Vibration Speeds</b>    | 120   |
| <b>Vibration Force</b>     | 15.4 G's  |
| <b>Operating Frequency</b> | 1Hz-60Hz  |
| <b>Programs</b>            | 9+: 3 Pre-Programmed, 6 User Defined (w/ USB), + hundreds available |

# Machine Diagram

1. Screw (M5x8)
2. Display Board
3. Signal Line Connectors
4. Decorative Cover
5. Handrail
6. Tower
7. Screw (M8x55)
8. Screw (M8x20)
9. Gaskets
10. Step Board
11. Base

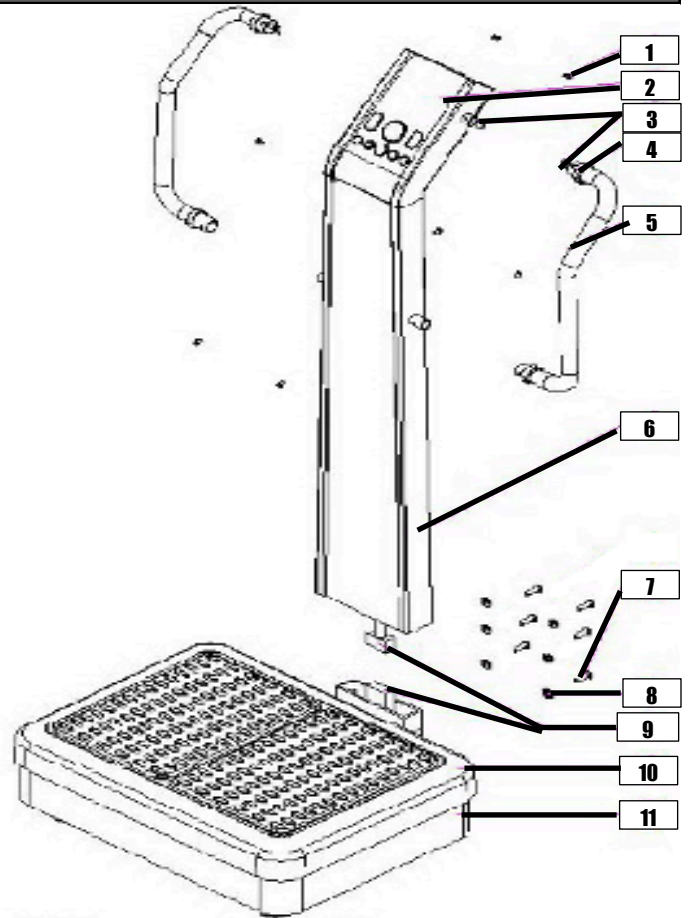

# Assembly Instructions

1. Place the base on a flat surface.
  - **NOTE:** The base is extremely heavy. We recommend two people removing it from the packaging.
2. Using the tower, connect the upper and lower signal lines.
  - **NOTE:** We recommend having one person hold the tower firmly, while the other connects the signal lines.
3. Attach the base and tower together.
  - **NOTE:** Use care when attaching the pieces, as they can jam the signal cables, which will result in the machine not working as intended.
4. Lock the base and tower together tightly with the appropriate screws (included).
5. Install the handrails to the tower with the appropriate screws (included).
6. Adjust the horizontal cushion to set the machine steady.
7. Connect the power plug.
8. Turn on the power switch (located on the backside of the base).
9. Press the START button.



# Display & Control Panel Diagram

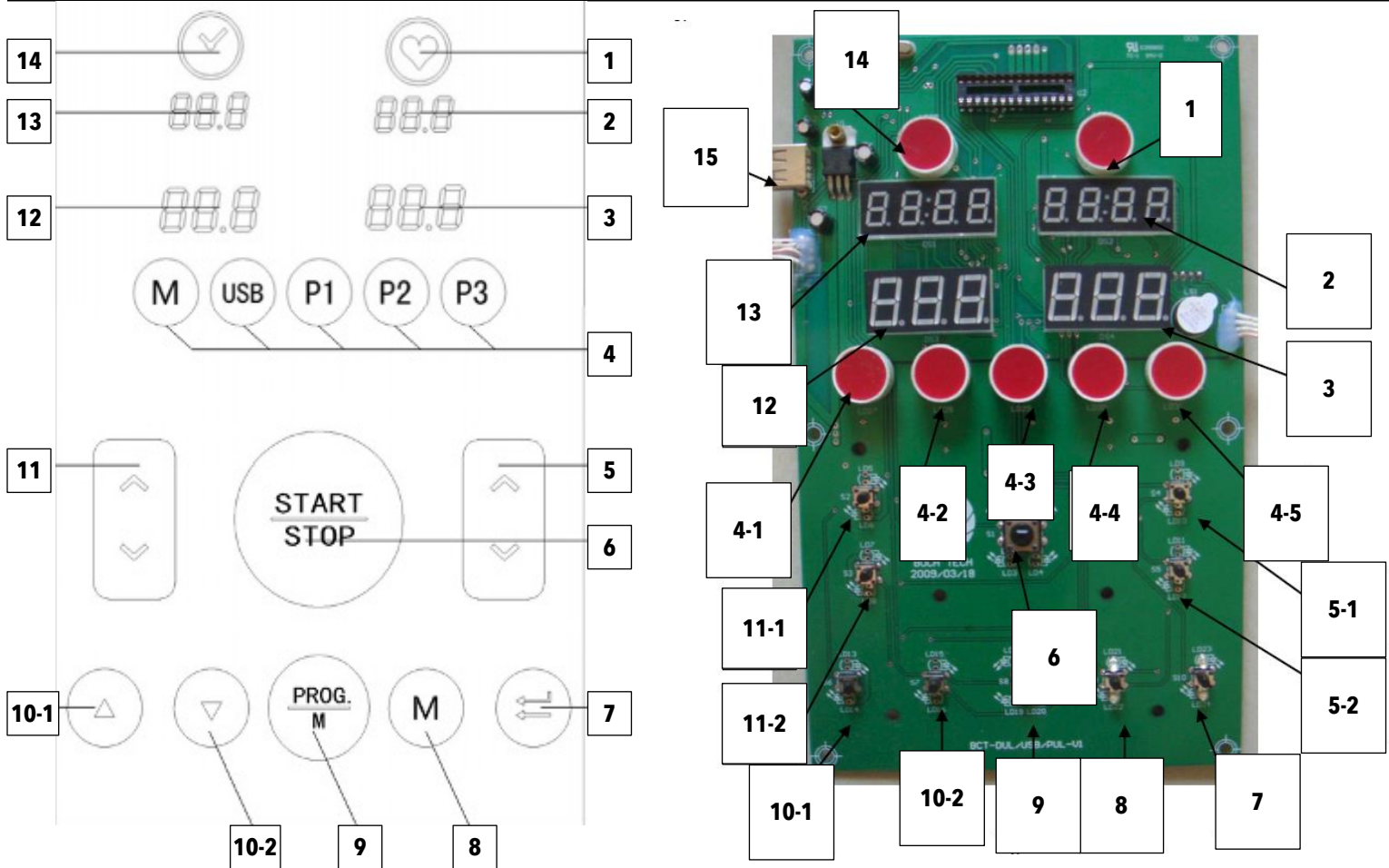

# Control Panel Operation

1. The **pulse indicator light** flickers when the machine detects your pulse.
2. The **linear vibration time display** displays the linear vibration time or displays the linear and horizontal vibration times combined. The preset time is 0-20 minutes.
3. The **linear vibration speed display** displays the linear vibration speed, ranging from L00-L60
  - **NOTE:** When the display reads "L00", the horizontal vibration will not work.
4. The mode/program lights will turn on when selected. *[see page 07]*
  - 4.1. Manual mode
  - 4.2. USB
  - 4.3. Auto Program (P1)
  - 4.4. Auto Program (P2)
  - 4.5. Auto Program (P3)
5. The **linear vibration time/speed button** will adjust the linear vibration time when displaying time, or the linear vibration speed when in manual mode.
  - 5.1. **(+)** will increase linear vibration time/speed
  - 5.2. **(-)** will decrease linear vibration time/speed

6. The **on/off button** turns the display on and off.
7. The **time button** adjusts the vibration time when the machine is not in manual mode.
8. The **program button** changes the program mode. Pressing the button cycles through manual mode and auto program P1-P3, when a USB is not inserted, or cycles through USB user programs U1-U6, when a USB is inserted.
9. The **mode/time change button** cycles between displaying mode or time on both #2 and #14 displays simultaneously.
10. The **time/speed buttons** adjust the vibration time, when displaying time, or the vibration speed, when displaying speed.
  - 10.1. **(+)** will increase vibration time or speed by two
  - 10.2. **(-)** will decrease vibration time or speed by two
11. The **horizontal vibration time/speed button** will adjust the horizontal vibration time when displaying time, or the horizontal vibration speed when in manual mode.
  - 11.1. **(+)** will increase horizontal vibration time/speed
  - 11.2. **(-)** will decrease horizontal vibration time/speed
12. The **horizontal vibration speed display** displays the horizontal vibration speed, ranging from H00-H60
  - **NOTE:** When the display reads "H00", the linear vibration will not work.
13. The **horizontal vibration time display** displays the horizontal vibration time or displays the horizontal and linear vibration times combined. The preset time is 0-20 minutes.
14. The **time indicator** indicates the time.
15. The **USB interface** is where the (optional) USB gets plugged in.

## Modes & Programs

### Manual Mode

There are three (3) preset manual programs. Each program runs for ten (10) minutes.

- **P1: Cardio** - both vibration modes work together, with the speed changing one (1) time every five (5) seconds.
- **P2: Detoxify** - both vibration modes work together, with the speed changing one (1) time every five (5) seconds.
- **P3: Full Body** - one (1) vibration mode works while the other does not, with the speed changing one (1) time every two (2) seconds.

### User Programs

You can define the program by using a USB flash drive and connecting it to the machine.

### How To Use Modes & Programs

1. Open the reset interface by double clicking 'BOCH-USB-DUL' under 'BOCH-USB' in the USB flash drive.
2. You can choose U1-U6 by clicking *User's Defined Program*.
3. Fill in the data as desired. (Speed range: 0-60 seconds)
  - Checking *ONCE* means that the vibration mode will only run that pattern once.
  - Checking *LOOP* and entering running time (1-12 minutes) means that the vibration mode will repeat during the running time.
4. After amending the data to your preference, you will see the *Running Column* change. The height of the column indicates speed, while the width of the column indicates the time.
5. Function buttons access the data files.
  - *LOAD FACTORY* accesses the factory data.
  - *LOAD DEFAULT* accesses the data that you set.
  - *SAVE DEFAULT* saves the data as 'active.'

6. Insert the USB flash drive into the machine.

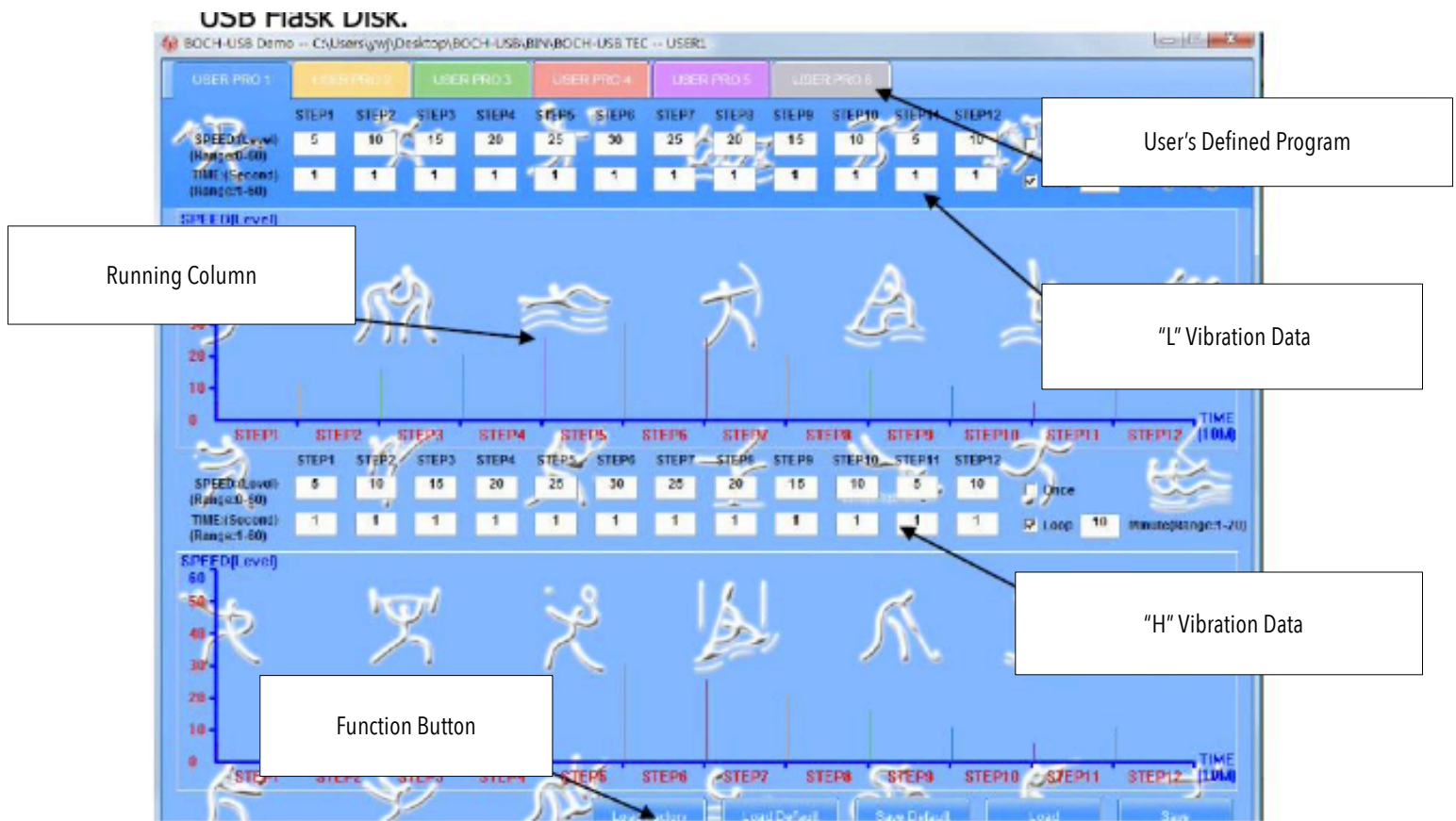

## Operating Instructions

1. Insert the power plug into the power socket on the back side of the base (vibration) plate, check the voltage, and switch on.
2. Prepare for your desired posture on the vibration plate.
3. Press *START* to begin the program.
  - **NOTE:** When using automatic program modes, the speed cannot be adjusted manually. The machine will alternate the vibration speed at the preset intervals.

To use the pulsimeter, hold the metal sheet on the handrail when the machine is stopped. The pulse light will flicker according to your pulse and will display "ECG-P085," with the last three digits being your pulse. If the pulse light does not flicker, check if the metal sheet is clean and dry.

**It is strongly advised to drink at least 20oz of water after each use.**

For best results, complete one session in the morning and one session in the evening, with a minimum 15-20 minute break between sessions.

**WARNING: DO NOT USE THE MACHINE FOR MORE THAN TEN (10) MINUTES PER SESSION OR TWENTY (20) MINUTES PER DAY.**



# Warranty Information

## **FIVE (5) YEAR - Limited Warranty**

The manufacturer warrants that this machine, when subject to normal and proper use, will be free from manufacturing defects for a period of five (5) years from the date of purchase. Should any defect occur during the specified time period, the manufacturer will repair the defective product, or provide replacement parts and components material, at its own option. The manufacturer also reserves the right to issue a full refund of the purchase price in lieu of repair or replacement. **This warranty is not transferable.** This warranty replaces all other oral or written warranties, liabilities or obligations of the manufacturer. Pertinent state law shall control for what period of time following the purchase a consumer may seek a remedy under the implied warranty of merchantability or fitness for a particular purpose. In no event shall the manufacturer be liable for consequential or incidental damages of any kind resulting from the breach of this warranty. Some states do not allow limitations on - or the exclusion of - incidental or consequential damages, so the above exclusions may not apply to you. This warranty gives you specific legal rights, and you may also have other rights which vary from state to state.

## Quick Reference

The 'H' (horizontal) vibration is the *triangular oscillation vibration*, which is good for muscle contraction. This type of vibration is the one that gives you a workout.

The 'L' (linear) vibration is the more subtle *spiral vibration*, which is more therapeutic than the 'H' vibration. It helps improve circulation, reduce inflammation, assists with muscle recovery, etc.

Using both vibrations at once intensifies the effect of each vibration. There really isn't a "magic" way to use the machine; the most important part is using it consistently - which is how you'll see the best results.

Different users will use the machine at different speeds. An elderly person, for example, would use the machine at lower speeds while an elite athlete would use higher speeds. As a general recommendation, start out at speeds below 30 for the first few weeks of use and slowly go faster and faster as your body allows. Experimenting with varying speeds is also good to do, as different speeds affect your body differently. This is where the preset programs (P1-3) come in handy - they change the speed automatically and frequently, which gives your body a different stimulus than simply maintaining a consistent speed. When keeping the speed consistent, pick five (5) different positions (see pg. 9-12) and hold each position for 1-2 minutes. When the speed varies, stand with legs straight, bend your knees slowly, hold it, and return to the starting position.

It's recommended to use the machine twice per day: in the morning, use a consistent speed, and in the evening, utilize the varying speeds. Be sure to give your body at least one day of rest per week. Be careful not to overdo it in the beginning; this is a common mistake.

**VBXWellness**

**VBX Wellness is a registered brand of M&E Sales, LLP**

**150 W 88th St, Ste 114  
Bloomington MN 55420**

**952.884.0326  
vbxwellness@gmail.com**